



Phones: 99260211 - 99260212 -99260213

**Board of Intermediate Education**  
**Bakhtiyari Youth Center,**  
**North Nazimabad, Karachi-74700**

NO.BIE/AG./L&N/72/2017

Dated: 29-11-2017

Sindh Govt. Website  
www.sindh.govt.pk

Board's Website  
http://www.blek.edu.pk

PPRA Sindh Govt. Website  
www.pprasindh.govt.pk

### **RE-TENDER NOTICE FOR SUPPLY** **OF OFFICE FURNITURE**

Sealed Tenders are invited from reputed & financially sound manufacturers / companies for Steel / Wooden furniture duly registered with the Income Tax / Sale Tax Department for supply of Office Furniture as per specification given in the Bidding Documents.

Bidding Documents may be obtained from the office of the Admin General Section on production of an application on the original letter head of the firm, against payment of Rs. 1,000/- (Non-refundable) in shape of pay order in favour of Secretary Board of Intermediate Education, Karachi on any working day between 10:00 A.M. to 05:00 P.M. from 07-12-2017 to 21-12-2017.

Tender may be submitted latest by 02:30 P.M. on 22-12-2017 and will be opened on the same day at 03:00 P.M. in presence of the tenderer or their representatives who wish to be present on the occasion; General Sales Tax Registration / Income Tax Certificate must be accompanied with the Tender.

In case of the any member of the Procurement committee is out of headquarters or in case of Public holiday or any extraordinary circumstances owing to law and order situation or a natural calamity the bid shall be opened on next working day.

Tender must be accompanied by Pay Order @ 3% of the quoted value of the Tender as Bid Security in favour of the Secretary, Board of Intermediate Education Karachi.

"The Procuring Agency may reject all or any bid subject to the relevant provision of SPPRA rules."

(AZEEM AHMED)  
SECRETARY ACTING  
(SYED HADI HASAN)  
DEPUTY SECRETARY

INF-KRY: 5072/12

محمد شوری کے خلاف تحریک

Say No to Corruption



## **Board of Intermediate Education**

Bakhtiari Youth Center, North Nazimabad,  
Karachi - 74700

Phones:

99260211  
99260212  
99260213

NO.BIE/AG./L&N/ 72 /2017

Dated: **29-11-2017**

**Sindh Govt. Website**  
[www.sindh.govt.pk](http://www.sindh.govt.pk)

**Board's Website**  
<http://www.biek.edu.pk>

**PPRA Sind Govt. Website**  
[www.pprasindh.govt.pk](http://www.pprasindh.govt.pk)

### **RE-TENDER NOTICE FOR SUPPLY OF OFFICE FURNITURE**

Sealed Tenders are invited from reputed & financially sound manufacturers /companies for Steel / Wooden furniture duly registered with the Income Tax / Sale Tax Department for supply of Office Furniture as per specification give in the Bidding Documents.

Bidding Documents may be obtained from the office of the Admin General Section on production of an application on the original letter head of the firm, against payment of Rs.1,000/= (Non-refundable) in shape of pay order in favour of Secretary Board of Intermediate Education, Karachi on any working day between 10:00 A.M to 05:00 P.M from **07-12-2017** to **21-12-2017**.

Tender may be submitted latest by 02:30 P.M on **22-12-2017** and will be opened on the same day at 03:00 P.M in presence of the tenderers or their representatives who wish to be present on the occasion; General Sales Tax Registration / Income Tax Certificate must be accompanied with the Tender.

In case of the any member of the Procurement committee is out of head quarter or in case of Public holiday or any extraordinary circumstances owing to law and order situation or a natural calamity the bid shall be opened on next working day.

Tender must be accompanied by Pay order @ 3% of the quoted value of the Tender as Bid Security in favour of the Secretary, Board of Intermediate Education Karachi.

"The Procuring Agency may reject all or any bids subject to the relevant provision of SPPRA rules."

**(AZEEM AHMED)**  
**SECRETARY ACTING**

**Copy to:**

- i) P.S. to Chairman
- ii) P.A. to Secretary
- iii) SPPRA
- iv) Guard file

**(SYED HADI HASAN)**  
**DEPUTY SECRETARY**



**Board of Intermediate Education**  
Bakhtiar Youth Center, North Nazimabad,  
Karachi - 74700

Phones } 99260211  
          } 99260212  
          } 99260213  
Fax:     } **99260203**  
          } **99260208**

NO.BIE/ADMIN GEN. 1399B/2016

DATED: 28-11-2016

**NOTIFICATION**

In pursuance of Rule-31 of Sindh Public Procurement Rules 2010, with the approval of the competent authority, a '**COMPLAINT REDRESSAL COMMITTEE**', comprising the following, is hereby constituted to address the complaints of bidders that may occur during the procurement proceedings:

01	Chairman Board	Convener
02	Representative of the Account General Sindh	Member
03	An independent professional from the relevant field concerning the procurement process in question, to be nominated by the Chairman Board of Intermediate Education, Karachi	Member

**Terms of Reference:**

On receipt a complaint from an aggrieved bidder may, *if satisfied:*

- prohibit the Procurement Committee from acting or deciding in a manner, inconsistent with SPPRA rules and regulations;
- annul in whole or in part, any unauthorized act or decision of the Procurement Committee;
- reverse any decision of the Procurement Committee or substitute its own decision for such a decision;
- may ask to provide any record relevant to the complaint or bidding.
- shall announce its decision within seven days receipt of a complaint.

**Copy to:-**

1. P.S to Chairman
2. P.A to Secretary
3. P.A to Controller of Examinations
4. S.P.P.R.A.
5. Officer concerned
6. Guard File

  
**(AZEEM AHMED)**  
**SECRETARY (ACTING)**

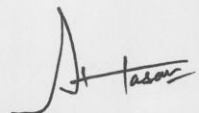
  
**(SYED HADI HASAN)**  
**DEPUTY SECRETARY**



**Board of Intermediate Education**  
Bakhtiyari Youth Center, North Nazimabad,  
Karachi - 74700

Phones

99260211  
99260212  
99260213

No. BIE/AG/L&N/60/2017

Dated: 08-11-2017

## NOTIFICATION

With reference to this office Notification No: BIE/ADMN GEN/1532/2017 dated 28-03-2017 and with the approval of Competent Authority, a 'Procurement Committee' comprising the following is hereby re-constituted to invite, evaluate and finalize the Bids for Procurement of Goods & Services for BIE, Karachi and recommend the successful Bidder / Firm to the competent authority for award of contract:

- |  |          |
|--|----------|
| 1. Secretary Board   | Convener |
| 2. Controller of Examinations  | Member   |
| 3. Audit Officer   | Member   |
| 4. Prof. Muhammad Saleem Ghauri<br>Principal D.J. Sindh Govt. Sc. College,<br>Karachi. | Member   |
| 5. Prof. Babar Shah Khan<br>Assistant Professor (Jinnah Govt. College)                 | Member   |

### Terms of Reference:

- To Select appropriate method of Procurement, as specified in SPPRA Rules.
- To prepare bidding / pre-qualification documents.
- To prepare invitation of bids / pre-qualification notice.
- To carry-out technical as well as financial evaluation of the bids.
- To prepare bid evaluation report.
- To make recommendation for the award of contract or otherwise, to the competent authority.
- To perform any other function ancillary and incidental thereto.

Copy to:

- 1) P.S to Chairman
- 2) P.A to Secretary
- 3) P.A to Controller of Examinations
- 4) S.P.P.R.A
- 5) Guard File

  
(AZEEM AHMED)  
SECRETARY ACTING

  
(SYED HADI HASAN)  
DEPUTY SECRETARY

روزنامہ جنگ کراچی جمعرات 7 دسمبر 2017ء

## بورڈ آف انٹرمیڈیٹ ایجوکیشن



بختیاری یوتھ سینٹر، نارتھ ٹائم آباد کراچی-74700  
فون: 99260211, 99260212, 99260213

حکومت سندھ ویب سائٹ بورڈ کی ویب سائٹ PPRa سندھ گورنمنٹ ویب سائٹ

www.pprasindh.govt.pk http://www.biek.edu.pk www.sindh.govt.pk

No.BIE/AG./L&N/72/2017

Dated:29-11-2017

### آفس فرینچیز کی فراہمی کیلئے مکرر ٹینڈر نوٹس

بڑنگ دستاویزات میں دی گئی تصریح کے مطابق آفس فرینچیز کی فراہمی کیلئے ایکم ٹیکس/سیلز ٹیکس ڈی پارٹنٹ سے باقاعدہ رجسٹرڈ اسٹیل/کنکریٹ کے فرینچیز کیلئے معروف اور مالی طور پر مستحکم مینوفیکچررز/کمپنیز سے ستمبر ٹینڈرز مطلوب ہیں۔

بڑنگ دستاویزات، فرم کے اصل لیٹر ہیڈ پر درخواست پیش کرنے اور -/Rs.1000 (تاقابل واپسی) بھیکل پے آرڈر تک سیکرٹری بورڈ آف انٹرمیڈیٹ ایجوکیشن، کراچی کی ادائیگی کے مقابل 07-12-2017 تا 21-12-2017 کسی بھی کام والے دن صبح 10:00 بجے تا شام 05:00 بجے کے درمیان دفتر ایڈمن جرنل سیکشن سے حاصل کی جاسکتی ہیں۔

ٹینڈر 22-12-2017 کو دوپہر 02:30 بجے تک جمع کرایا جاسکتا ہے اور اسی دن سہ پہر 03:00 بجے صبح پر موجود رہنے کے خواہاں ٹینڈر دہندگان یا ان کے نمائندوں کی موجودگی میں کھولا جائے گا۔ جرنل سیکرٹری رجسٹریشن/ایکم ٹیکس اور SRB سرٹیفکیٹ ٹینڈر کے ہمراہ لازماً منسلک کیا جائے۔

پروکیورمنٹ کمپنی کے کسی رکن کے ہیڈ کوارٹر سے باہر ہونے یا عام تعطیل یا اسن واماں کی صورت حال یا قدرتی آفت کی وجہ سے کسی غیر معمولی صورت حال پیدا ہونے کی صورت میں پیشکش آئندہ کام والے دن کھولی جائے گی۔ ٹینڈر کے ہمراہ ٹینڈر کی درج کردہ رقم کا 3% کی شرح سے پے آرڈر بطور بڈ سیکورٹی بحق سیکرٹری، بورڈ آف انٹرمیڈیٹ ایجوکیشن کراچی لازماً منسلک کرنا ہوگا۔

”SPPRA رولز کی متعلقہ شقوں سے شروع پروکیورمنٹ ایجنسی تمام یا کسی پیشکش کو مسترد کر سکتی ہے۔“

(عظیم احمد)

قائم مقام سیکریٹری

INF-KRY:No.5072/17

سندھ میں تعلیم کی بہتری کے لئے، ملی + دنیا پیغام لکھ کر 8398 پر ایس ایم ایس کریں۔



**BOARD OF INTERMEDIATE EDUCATION,  
BAKHTIYARI YOUTH CENTER, NORTH NAZIMABAD,  
KARACHI-74700**

Phones:

99260211  
99260212  
99260213

**STANDARD BIDDING DOCUMENTS  
FOR  
NATIONAL COMPETITIVE BIDDING  
SINGLE STAGE – ONE ENVELOPE PROCEDURE  
  
TENDER FOR PROCUREMENT OF OFFICE  
FURNITURE**

*IN RESPECT OF THE  
BIEK/AG/L&N/ 72 /2017*

**PART ONE (FIXED)**

- Instructions to Bidders (ITB)
- General Conditions of Contract (GCC)



**BOARD OF INTERMEDIATE EDUCATION,  
BAKHTIYARI YOUTH CENTER, NORTH NAZIMABAD,  
KARACHI-74700**

**INSTRUCTIONS TO BIDDERS & GENERAL  
CONDITIONS OF CONTRACT:**

The Instructions to Bidders (ITB) and General Conditions of Contract (GCC) applied in this Contract shall be the same as per Standard Bidding Documents for Goods, issued by SPPRA. For further references the same may be downloaded from the Board's website <http://www.biek.edu.pk> and from the SPPRA's website [www.pprasinhd.gov.pk](http://www.pprasinhd.gov.pk) or it may be provided from this Office if it may be demanded by the bidder. Whenever there is a conflict, the provisions hereafter shall prevail over those in the Instructions to Bidders & General Conditions of Contract. The corresponding clause number of the ITB & GCC is indicated in parentheses.

**BID DATA SHEET**

<b>INTRODUCTION</b>		
<b>ITB 1.1</b>	Name of Contract	Procurement of Office Furniture
<b>ITB 4.1</b>	Name of Procuring Agency	<b>Board of Intermediate Education Karachi</b>
<b>ITB 6.1</b>	Procuring agency's address, telephone, telex, and facsimile numbers	Board of Intermediate Education, Bakhtiyari Youth Center North Nazimabad Tel: 99260211 99260212 99260213 Fax: 99260203 & 99260208
<b>ITB 8.1</b>	Language of the bid	English or Urdu

<b>BID PRICE AND CURRENCY</b>	
<b>ITB 11.2</b>	The price shall be in Pakistani currency inclusive of all Taxes, Transportation, Material and Labour charges involved therein.
<b>ITB 11.5</b>	During the entire period of bid validity, the price shall be fixed and the bidder will have to supply the required items as per specifications and quoted rates.



**BOARD OF INTERMEDIATE EDUCATION,  
BAKHTIYARI YOUTH CENTER, NORTH NAZIMABAD,  
KARACHI-74700**

<b>PREPARATION AND SUBMISSION OF BIDS</b>		
<b>ITB 13.3 (d)</b>	Qualification Requirements	<ul style="list-style-type: none"> <li>• 05 years experience in the relevant field</li> <li>• Turn-over of at least last three years having a sum of minimum Rs.2,500,000/-</li> <li>• Registration with Federal Board of Revenue (FBR), for Income Tax and Sales Tax in case of procurement of goods</li> <li>• Registration with the Sindh Revenue Board (SRB) in case of procurement of works and services</li> <li>• An Affidavit on Stamp Paper that the firm has never been Blacklisted</li> </ul>
<b>ITB 15.1</b>	Amount of bid security (refundable)	<ul style="list-style-type: none"> <li>• 3% of the bid price, which should be submitted in shape of Pay Order in the name of <b>Secretary, Board of Intermediate Education Karachi</b> and shall remain valid for a period of 28 days beyond the validity period for bid.</li> </ul>
<b>ITB 16.1</b>	Bid Validity Period	90 days from the date of opening of Tender.
<b>ITB 18.2 (a)</b>	Address for bid submission	The office of the <b>Superintendent, Administration General Section</b> (Chairman's Secretariat), Ground Floor, Board of Intermediate Education, Karachi.
<b>ITB 18.2 (b)</b>	IFB title and number	Title: Procurement of Office Furniture IFB No: <i>BIE/AG/L&amp;N/ 72 /2017</i> <i>Dated: 29 -11-2017</i>
<b>ITB 19.1</b>	Deadline for bid submission	<b><u>Friday 22<sup>nd</sup> December 2017 up to 2:30 p.m</u></b> Sealed bids duly filled-in, mentioning on top of the envelope <b>"Tender for Procurement of Office Furniture"</b>
<b>ITB 22.1</b>	Time, date, and place for bid opening	Bids duly stamped on each document must be submitted in the office of the <i>Admin General Section</i> (Chairman's Secretariat), Ground Floor, Board of Intermediate Education, Karachi, in a sealed cover on <b><u>22-12-2017</u></b> up to <b><u>2:30 P.M</u></b> and will be opened on the same day at <b><u>3:00 P.M</u></b> in the presence of bidders' representatives who wish to attend.
<b>ITB 25.4 (b)</b>	Delivery schedule	The delivery will have to be made at our site within stipulated time as mentioned in the Contract Award. Minimum time period will be at least 60 days after issuance of contract award which may be increased or decreased due to demand of time/situation.





**BOARD OF INTERMEDIATE EDUCATION,  
BAKHTIYARI YOUTH CENTER, NORTH NAZIMABAD,  
KARACHI-74700**

### **BID EVALUATION CRITERIA**

Bids of only those Bidders will be evaluated who can fulfill the Eligibility Criteria and enclose Bid Security.

Shortcomings in submission of documents related to Eligibility Criteria or non-submission of Bid Security or specimen/samples shall be rejected.

Prior to submission of bids, the bidders may obtain further information and completely satisfy themselves about the required items for which they are bidding for.

An interested bidder, who has obtained bidding documents, may request for clarification of contents of the bidding document in writing, and procuring agency shall respond to such queries in writing within three calendar days, provided they are received at least five calendar days prior to the date of opening of bid.

The offered products should be prime quality products. Cheap products of low quality or substandard shall not be accepted and the said bid shall be treated as Irresponsive.

**The evaluation shall be on accumulative cost basis so the bidders are advised to quote for all the items.**

Inferior, low quality or substandard products will be rejected and Security Money shall be forfeited and the bidder may also be blacklisted.

The bidder with the "Lowest Evaluated Cost" but not necessarily the "Lowest Submitted Price" shall be awarded the Procurement Contract.

## **SECTION III. SPECIAL CONDITIONS OF CONTRACT**

The following Special Conditions of Contract shall supplement the General Conditions of Contract. Whenever there is a conflict, the provisions herein shall prevail over those in the General Conditions of Contract. The corresponding clause number of the GCC is indicated in parentheses.

### **1. DEFINITIONS (GCC CLAUSE 1)**

1)	<b>GCC 1.1 (g)</b>	The Procuring agency is:	Board of Intermediate Education, Karachi.
2)	<b>GCC 1.1 (h)</b>	The Procuring agency's country is:	Islamic Republic of Pakistan.
3)	<b>GCC 1.1 (j)</b>	The Project Site is:	Same as GCC 1.1(g) mentioned above.

### **2. COUNTRY OF ORIGIN (GCC CLAUSE 3)**

All countries and territories as indicated in Part Two Section VI of the bidding documents, "Eligibility for the Provisions of Goods, Works, and Services in Government-Financed Procurement".



**BOARD OF INTERMEDIATE EDUCATION,**  
**BAKHTIYARI YOUTH CENTER, NORTH NAZIMABAD,**  
**KARACHI-74700**

**3. PERFORMANCE SECURITY (GCC CLAUSE 7)**

1)	<b>GCC 7.1</b>	The amount of performance security, as a percentage of the Contract Price, shall be Ten (10) percent of the Contract Price which should be submitted in shape of Pay Order in the name of <b>Secretary, Board of Intermediate Education Karachi.</b>
----	----------------	--

**4. RESOLUTION OF DISPUTES (GCC CLAUSE 28)**

The dispute resolution mechanism to be applied pursuant to relevant SPPRA Rules.

**5. GOVERNING LANGUAGE (GCC CLAUSE 29)**

1)	<b>GCC 29.1</b>	The Governing Language shall be:	English.
----	-----------------	----------------------------------	----------

**6. NOTICES (GCC CLAUSE 31)**

GCC 31.1 — Procuring agency's address for notice purposes:

Office of the Assistant Secretary, Admin General Section, Room No. 32, 1<sup>st</sup> Floor, Board of Intermediate Education, Karachi.

**7. PENALTY**

- 1) Preferred penalties according to the issue\subject may be imposed upon the Supplier(s) such as:
  - i. rejection of the unsatisfactory Supplied material
  - ii. Blacklisting of the firm
  - iii. Liquidity damages shall be imposed as per SPPRA Rules.
  - iv. forfeiting of whole Security amount

Anyone or more than one from the aforesaid penalties may be imposed upon the Supplier(s) in the following cases:

- a) In case of transgression/deviation of the time given in the Contract Award
- b) In case of transgression, deviation, mistake or low quality found in the supplied Item(s)
- c) In case the specification, quantity, rate or stuff of a Tender in certain item or items are approved and the Bidder backs out of his commitment on any pretext or fails to supply the material or complete the job in time or in the required criteria.

**8. SUBJECT TO RELEVANT SPPRA RULES,  
THE COMPETENT AUTHORITY RESERVES THE RIGHT TO:**

- (a) divert/distribute a particular work among different Bidders on the lowest approved rate(s) in the interest of the office due to demand of time/situation.
- (b) accept or reject all or any bid.
- (c) increase or decrease quantity without any notice at any time/stage subject to ITB Clause 29.



**BOARD OF INTERMEDIATE EDUCATION,**  
BAKHTIYARI YOUTH CENTER, NORTH NAZIMABAD,  
KARACHI-74700

**9. SPECIAL CLAUSE (TERMS & CONDITIONS)**

- 1) Under following conditions bid will be rejected:-
  - i. Conditional and telegraphic bids/tenders
  - ii. Bids not accompanied by Bid Security of required amount and form
  - iii. Bids received after specified date and time
  - iv. Bids of Blacklisted firms
- 2) Bids of only those Bidders will be evaluated who can fulfill the Eligibility Criteria and enclose Bid Security.
- 3) Shortcomings in submission of documents related to Eligibility Criteria or non-submission of Bid Security shall be rejected.
- 4) Prior to submission of bids, the bidders may obtain further information and completely satisfy themselves about the required items for which they are bidding for.
- 5) An interested bidder, who has obtained bidding documents, may request for clarification of contents of the bidding document in writing, and procuring agency shall respond to such queries in writing within three calendar days, provided they are received at least five calendar days prior to the date of opening of bid.
- 6) The offered products should be prime quality products. Cheap products of low quality or substandard shall not be accepted and the said bid shall be treated as Irresponsive.
- 7) Inferior, low quality or substandard products will be rejected and Security Money shall be forfeited and the bidder may also be blacklisted.
- 8) The bidder with the "Lowest Evaluated Cost" but not necessarily the "Lowest Submitted Price" shall be awarded the Procurement Contract subject to compatibility/suitability of the item(s).
- 9) The bidder shall supply the article(s) as per approved specifications mentioned in the Contract Award. The article(s) not found in conformity with the approved specifications shall be rejected at the risk & cost of the bidder.
- 10) The Contract Award may be assigned at any time during the period of bid validity.
- 11) The successful bidder will have to deposit **Performance Security @ 10%** of the value of Contract Award which is refundable after the satisfactory completion of supplies.
- 12) The amount of Performance Security is in addition to the amount of Bid Security which should be deposited by the successful bidder(s). Bid Security shall remain valid for a period of 28 days beyond the validity period for bids, whereas Performance Security shall be released ninety days beyond the date of completion of contract to cover defects liability period subject to final acceptance by the procuring agency.



**BOARD OF INTERMEDIATE EDUCATION,**  
**BAKHTIYARI YOUTH CENTER, NORTH NAZIMABAD,**  
**KARACHI-74700**

- 13) Placement of Contract Award will be subject to payment of Performance Security.
- 14) The material shall be delivered to Storekeeper, through the concerned Officers as the case may be, against delivery challan in triplicate along with samples of material in duplicate. Two copies of the bills and challan shall be retained by the Storekeeper while the third copy shall be returned to the supplier for his own record.
- 15) The items should be supplied strictly in accordance with the approved samples.
- 16) The delivery will have to be made at our site within stipulated time as mentioned in the Contract Award. Minimum time period will be at least one month after issuance of contract award which may be increased or decreased due to demand of time/situation.
- 17) SPPRA Rules-2010 (Amended 2013) shall strictly be followed.

**10. EQUIVALENCY OF STANDARDS AND CODES**

Reference to brand name, catalogue number or country where used, they should always be read with followed by the words “or at least equivalent.”

Reference to the required weight/grammage where used, a difference of plus/minus 05 should be tolerated.

## SECTION-IV. SCHEDULE OF REQUIREMENTS

**SCHEDULE OF REQUIREMENTS:**

The delivery will have to be made at our site within stipulated time as mentioned in the Contract Award. Minimum time period will be at least 60 days after issuance of contract award which may be increased or decreased due to demand of time/situation.



**BOARD OF INTERMEDIATE EDUCATION,**  
**BAKHTIYARI YOUTH CENTER, NORTH NAZIMABAD,**  
**KARACHI-74700**

**SECTION-V.**  
**TECHNICAL SPECIFICATIONS**  
**SUPPLY OF OFFICE FURNITURE**

**COMPUTER CHAIR**

- Revolving Chairs
- Bicast Leather
- Plywood seat with foam padding
- Cast aluminum base
- Chrome-plated steel tube arms
- Nylon casters

Below diagram for your reference:





**BOARD OF INTERMEDIATE EDUCATION,  
BAKHTIYARI YOUTH CENTER, NORTH NAZIMABAD,  
KARACHI-74700**

**OFFICE TABLE**

Size 4x2 ½ Frame shall be of pine wood. Two Drawers and one Cabinet on one side of standard size with One Drawer in center with locking system. The Frame of Drawers be on Deodar wood and bottom in ply wood with Chinese locking System. Three sides fully covered with Texture formica pressed on ¾ thick chip board with Bottom in hard Board of suitable grammage. Provision for foot rest be made. Finishing with sprit polish lock 2x2 pine wood covered.

Below diagram for your reference:





**BOARD OF INTERMEDIATE EDUCATION,  
BAKHTIYARI YOUTH CENTER, NORTH NAZIMABAD,  
KARACHI-74700**

**COMPUTER TROLLEY**

<b>Table Size</b>	Length 121cm, Width 60 cm, Height 76 cm
<b>Made</b>	Wood (Shesham)
<b>Color</b>	Brown Mahogany Wood
<b>Drawers / Cabinet</b>	2 Drawers with locks along with 1 cabinet on one side and 1 CPU box on the other side.
<b>Keyboard Tray</b>	1 Keyboard tray as per the below diagram
<b>Dimensions</b>	Please follow the below diagram for dimensions and design:

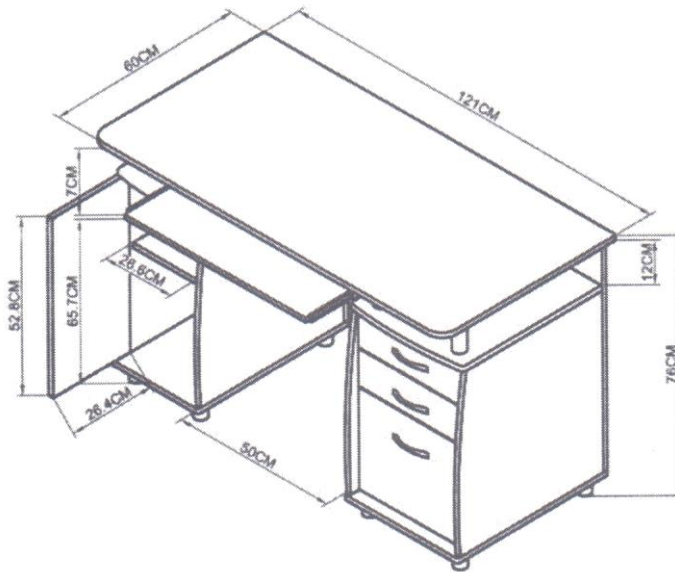

Size: 121W x 60D x 76H CM



**BOARD OF INTERMEDIATE EDUCATION,**  
**BAKHTIYARI YOUTH CENTER, NORTH NAZIMABAD,**  
**KARACHI-74700**

**OFFICE CHAIR**

<b>Size</b>	Office Chair of Standard Size
<b>Seat /Back</b>	Seat and Back Cushioned
<b>Made</b>	Shesham Wood
<b>Color</b>	Brown Mahogany Wood

Below diagram for your reference:







**BOARD OF INTERMEDIATE EDUCATION,  
BAKHTIYARI YOUTH CENTER, NORTH NAZIMABAD,  
KARACHI-74700**

**EXECUTIVE / OFFICER CHAIR**

- Revolving Chair
- Adjustable lumbar support and instant seat height adjustment.
- Metal 5-prong base
- Height / Width adjustable arms with soft and durable urethane pads.
- Best quality leather cushioning
- Back Rest
- Color Black
- Minimum Dimension:  
Seat Height 18-22 inches  
Overall Height 45-48 inches  
Backrest Width 18-20 inches  
Backrest Height 24-26 inches  
Overall Depth 20-24 inches  
Base Diameter 25-27 inches

Below diagram for your reference:

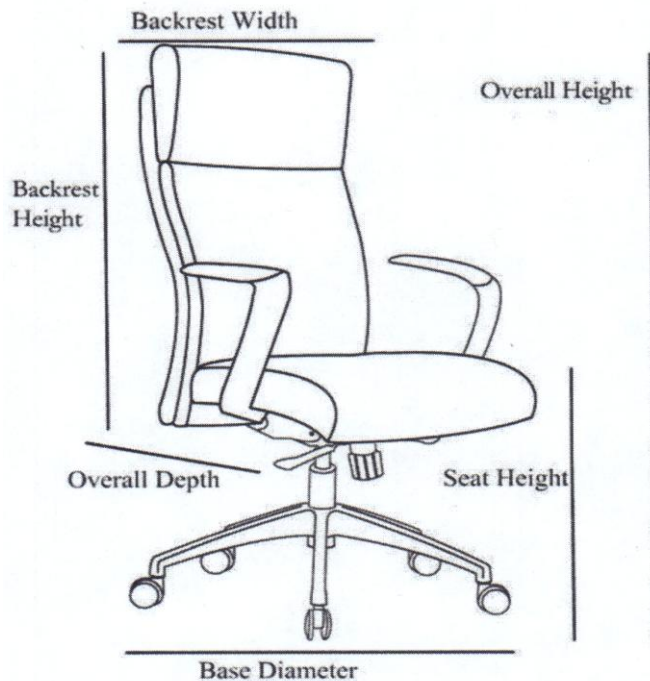



**BOARD OF INTERMEDIATE EDUCATION,  
BAKHTIYARI YOUTH CENTER, NORTH NAZIMABAD,  
KARACHI-74700**

**OFFICER TABLE**

<b>Table Size</b>	Length 72 inches, Width 36 inches, Height 30 inches
<b>Made</b>	Wood (Shesham)
<b>Color</b>	Brown Mahogany Wood
<b>Drawers / Cabinet</b>	3 drawers with locks on one side while one drawer and cabinet on other side
<b>Side racks Dimension</b>	Length 36 inches, Width 18 inches, Height 30 inches, with 1 Keyboard tray
<b>Dimensions</b>	Please follow the below diagram for design:





**BOARD OF INTERMEDIATE EDUCATION,**  
**BAKHTIYARI YOUTH CENTER, NORTH NAZIMABAD,**  
**KARACHI-74700**

**VISITOR CHAIRS FOR BPS-17 AND ABOVE**

- Best quality cushioning
- Color Brown Mahogany Wood
- Dimensions:

Seat Height 18 inches

Overall Height 36 inches

Backrest Width 20 inches

Overall Depth 18 inches

Base Diameter 25 inches

Please refer to the below picture for design:





**BOARD OF INTERMEDIATE EDUCATION,  
BAKHTIYARI YOUTH CENTER, NORTH NAZIMABAD,  
KARACHI-74700**

**STEEL ALMIRAH**

Made	Steel 18 Gauge
Color	Gray
Dimensions	Height 72 inches, Width 46 inches, Depth 18 inches
Shelves	Five shelves
Lock	Chinese Locking System

Please refer to the below picture for design:





**BOARD OF INTERMEDIATE EDUCATION,  
BAKHTIYARI YOUTH CENTER, NORTH NAZIMABAD,  
KARACHI-74700**

**FILE CABINETS**

Size	54x18x24
Made	Steel 18 Gauge
Color	Hammer Paint
Drawers	05 Drawers with handles insides with Name tags (pockets)
Locking System	Channel System with Imported Lock

**Please refer to the below picture for design:**





**BOARD OF INTERMEDIATE EDUCATION,  
BAKHTIYARI YOUTH CENTER, NORTH NAZIMABAD,  
KARACHI-74700**

**STEEL RACKS**

Metal Shelving, Freestanding, Open, Material Steel, Gauge 14,  
Number of Shelves 5, Width 72 In., Depth 24 In., Height 84 In.,  
Shelf Capacity 3000 lb., 1-1/2 In. Increments, Gray, Finish Powder Coated,  
Shelf Type Solid.

**Please refer to the below picture for design:**





**BOARD OF INTERMEDIATE EDUCATION,  
BAKHTIYARI YOUTH CENTER, NORTH NAZIMABAD,  
KARACHI-74700**

**CENTER TABLE / MEETING TABLE (FOLDING)**

<b>Table Size</b>	Length 72 inches, Width 36 inches, Height 30 inches
<b>Made</b>	Wood (Shesham) Frame Iron / Steel
<b>Color</b>	Brown Mahogany Wood

**Please refer to the below picture for design:**





**BOARD OF INTERMEDIATE EDUCATION,**  
**BAKHTIYARI YOUTH CENTER, NORTH NAZIMABAD,**  
**KARACHI-74700**

**VISITOR CHAIR (PUBLIC DEALING)**

<b>Measurements</b>	L174 xW78.7 x H77.5 cm
<b>Material</b>	PP Plastic with Metal Frame
<b>Back:</b>	PP Plastic
<b>Seat:</b>	PP Plastic
<b>Finishing:</b>	Powder Coating

**Please refer to the below picture for design:**







**BOARD OF INTERMEDIATE EDUCATION,  
BAKHTIYARI YOUTH CENTER, NORTH NAZIMABAD,  
KARACHI-74700**

**CHAIR FOR ASSESSMENT**

<b>Material:</b>	PP Plastic with Metal Frame
<b>Armrest:</b>	Without Armrest
<b>Folded:</b>	Unfolded
<b>Condition:</b>	New
<b>Back:</b>	PP Plastic
<b>Seat:</b>	PP Plastic
<b>Finishing:</b>	Powder Coating
<b>Tube Thickness:</b>	1.2mm
<b>Frame:</b>	Iron
<b>Tube:</b>	25mm Dia
<b>Cbm:</b>	0.038cbm

**Please refer to the below picture for design:**





**BOARD OF INTERMEDIATE EDUCATION,**  
**BAKHTIYARI YOUTH CENTER, NORTH NAZIMABAD,**  
**KARACHI-74700**

**FINANCIAL PROPOSAL**

S.No.	Name of Article	Unit / Qty	Unit Price	GST	Total Price
1.	Computer Chair	62			
2.	Office Table	108			
3.	Computer Trolley	25			
4.	Office Chair	154			
5.	Executive /Officer Chair	47			
6.	Officer Table	28			
7.	Visitor Chair (BPS-17 and above)	90			
8.	Steel Almirah	41			
9.	File Cabinets	45			
10.	Steel Racks	47			
11.	Center / Meeting Table (Folding)	70			
12.	Visitor Chair (Public Dealing) 3 seater	20			
13.	Chair for Assessment	400			

**Note: All Items must be local made imported items will not accepted.**

**Name of Firm**

**(Signature & Stamp)**



**BOARD OF INTERMEDIATE EDUCATION,**  
**BAKHTIYARI YOUTH CENTER, NORTH NAZIMABAD,**  
**KARACHI-74700**

	<i>Rupees In Words</i>	<i>Rupees In Figures</i>
Total cost of the Bid: <i>(as offered by the Bidder)</i>		
3% (three percent) amount of the Bid Price Bid Security (Refundable)		
10% (ten percent) amount of the Contract Price Performance Security (Refundable)		



**BOARD OF INTERMEDIATE EDUCATION,**  
BAKHTIYARI YOUTH CENTER, NORTH NAZIMABAD,  
KARACHI-74700

<b>SUMMARY OF TURN-OVER OF LAST THREE YEARS</b>		
<b>YEAR-2014</b>	<b>YEAR-2015</b>	<b>YEAR-2016</b>
<b>TOTAL:</b>		

## **CERTIFICATE**

I/We have carefully read & understood the Terms & Conditions whatever has been stated herein the enclosed pages and abide to the same. I/We guarantee to supply/deliver/install the items exactly in accordance with the requirements and enclosed the Bid Security payable to Board of Secondary Education, Karachi.

SIGNATURE WITH DATE:

\_\_\_\_\_

NAME OF FIRM:

\_\_\_\_\_

ADDRESS OF FIRM:

\_\_\_\_\_

\_\_\_\_\_

FULL NAME OF CONCERNED PERSON:

\_\_\_\_\_

CNIC NUMBER:

\_\_\_\_\_

POSITION HELD IN:

\_\_\_\_\_

PHONE NUMBER(S):

\_\_\_\_\_

MOBILE NUMBER(S):

\_\_\_\_\_

FAX NUMBER(S):

\_\_\_\_\_

NATIONAL TAX NUMBER:

\_\_\_\_\_

GENERAL SALES TAX NUMBER:

\_\_\_\_\_

STAMP OF THE FIRM:

\_\_\_\_\_

PAY ORDER NUMBER:

\_\_\_\_\_

BANK & BRANCH NAME:

\_\_\_\_\_

DATED:

\_\_\_\_\_

FOR RUPEES:

\_\_\_\_\_

DRAWN:

\_\_\_\_\_

as Bid Security is enclosed herewith.